

# VIDEO PRODUCTS

Composite Video, Computer and Component Video,  
Digital Video, Cable Compensation,  
Signal Switching, Data Conversion,  
Building Blocks, Video Amplifiers

**intersil™**



**SIMPLY SMARTER™**

# INTERSIL VIDEO PRODUCTS



Welcome to Intersil's Video Product Selection Guide. Intersil has always had a wide variety of Video ICs and 2011 is no exception. From basic building-blocks to highly-integrated innovative solutions, Intersil offers a wide range of Video products. Video amplifiers, multiplexers, crosspoints, and sync separators form a solid foundation for analog video, while the fully-automatic ISL5960x MegaQ family of adaptive equalizers for Cat x or Coax cables exemplifies the state-of-the-art mixed-signal solutions Intersil provides.

Intersil is also helping digital video go further. Intersil is home to the world's first HDMI/DVI regenerators, with a jitter-removing CDR on each channel. The QLX4270 family of active DisplayPort cables can reach 20m over 32-gauge twinax cable or 5m over an impossibly thin 40-gauge cable! And when you want to build a bridge between the analog and digital video worlds, we have the lowest-jitter, highest-performance Video Analog Front Ends on the planet. The ISL51002 and ISL98003 AFEs will even measure the sync signals and automatically find the best sampling phase while they're at it!

This guide is designed to be used in one of two ways. The first half (page 4-9) is organized by application – Composite, Computer & Component, and Digital Video. The 2nd half (page 10-19) is organized by function – Cable Compensation, Signal Switching, Data Conversion, Building Blocks and Amplifiers.

Thanks for your interest in Intersil's Video Products.

## CONTENTS

### SELECTING VIDEO ICs BY APPLICATION

COMPOSITE VIDEO .....	4
COMPUTER AND COMPONENT VIDEO .....	6
DIGITAL VIDEO .....	8

### SELECTING VIDEO ICs BY FUNCTION

CABLE COMPENSATION .....	10
SIGNAL SWITCHING.....	12
DATA CONVERSION.....	14
BUILDING BLOCKS.....	16
VIDEO AMPLIFIERS.....	18

**INTERSIL**

# VIDEO PRODUCTS

## SECURITY SYSTEM BLOCK DIAGRAM

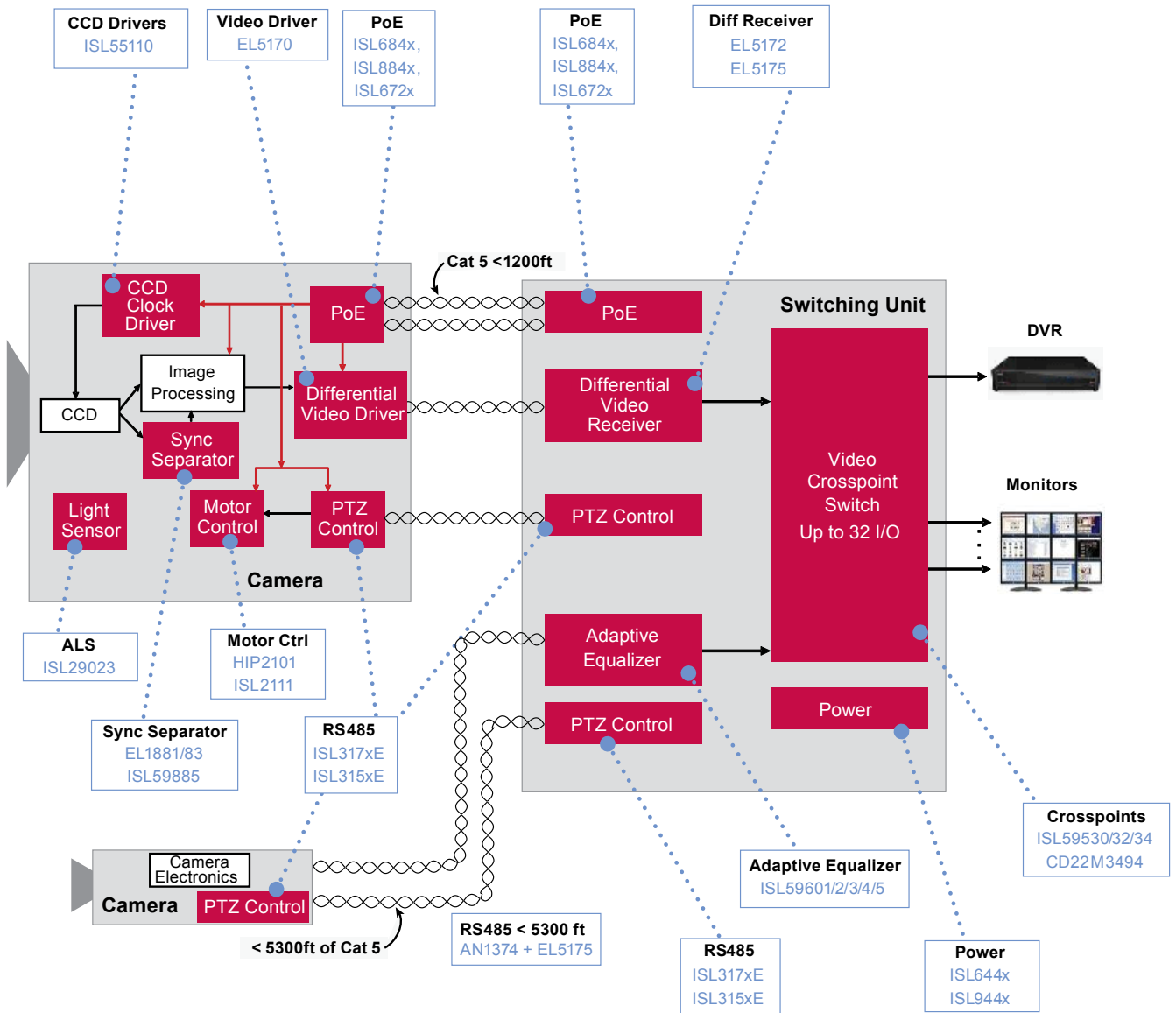

### COMPOSITE VIDEO

Although there are many new video standards offering higher and higher resolutions, composite video is still used in many different areas. One such area is security video, where video feeds are not only transmitted from the cameras to a monitoring location, but recorded and stored in case the video is needed later. Using a composite video signal helps reduce the amount of data storage required. As buildings and campuses get larger, so does the need to extend the distance between video camera and the monitoring station to cover these larger areas. Governments are now installing cameras in busy city areas for crowd monitoring, crime reduction and traffic monitoring, all increasing the areas that need to be monitored.

Another area is information distribution, for example sending images of information around an airport or shopping center. Composite video is the perfect signal to use for sending video over distances greater than 1000ft (300m).

Coaxial cables have been the standard cable for video transmission for a long time, but they are expensive, bulky and not that easy to install. They are good for the high frequencies contained in the video signal, but they are also lossy (mainly at low frequencies) which limits the distances they can transmit video. Twisted pair cables, like Cat 5 and Cat 6 (Ethernet cables), have grown in popularity over the last decade because they are so cheap and easy to use. These cables were not designed for analog video and are very lossy, particularly at high frequencies, which historically has limited the distance over which they can be used. Intersil's new MegaQ range of equalizers overcome the limitations of these cables and enable video transmission to reach up to 5 times further (1 mile/1.6 km) than before.

If you are interested in composite video decoders, take a look at our new product range from Intersil Techwell at [www.techwellinc.com](http://www.techwellinc.com)

#### Adaptive Equalizer

ISL59601,  
ISL59602,  
ISL59603,  
ISL59604,  
ISL59605

#### MegaQ: 1 MILE (1600M) ADAPTIVE COMPOSITE VIDEO EQUALIZER

The ISL5960x are a family of single-channel adaptive equalizers designed to automatically compensate for long runs of Cat 5, Cat 6 and Coaxial cables, producing high-quality video output with no user interaction. The ISL59605 can compensate for up to 60dB of signal loss and so can extend video transmission to 1 mile of Cat X or Coax cables.

Cable Type	Maximum Length Supported
<b>Copper-Core</b>	
Cat 5/Cat 5e	5300ft / 1600m
Cat 6	5600ft / 1700m
Coaxial - RG-59	6000ft / 1800m
Cat 2/Cat 3 (telephone wire)	3000ft / 900m
Belden IMSA Spec 39-2 581718 (3-pair traffic light cable)	5300ft / 1600m
<b>Non-Copper-Core*</b>	
Cat 5/Cat 5e (Copper-Coated Aluminum Core)	2000ft / 600m
Coaxial - RG-59 Copper-Coated Steel Core	1500ft / 450m

\*Image quality will be significantly improved over unequalized cable, but there will still be some image smearing due to the high resistance of the core material.

#### KEY FEATURES

- Equalizes Composite Video over 1 Mile of Cat X or Coax cable
  - Automatic cable-type compensation
  - Automatic color/monochrome detection
  - Automatic NTSC or PAL support
  - Automatic polarity correction (inverts differential pair polarity if cable connected backwards)
  - No minimum length required
- Single-Chip Solution for Fully Automatic Equalization
  - No user settings/adjustments necessary
  - Image quality is not dependent on the installer making adjustments
- Continuous Mode adjusts for any variations in the system (such as temperature), whilst one of the Locking Modes can be used to freeze equalization in extremely noisy environments
- Receive-side-only solution
  - No active silicon is required on the transmit side

Part #	Cat 5 Cable Length
ISL59601	1000ft or 300m
ISL59602	2000ft or 600m
ISL59603	3000ft or 900m
ISL59604	4000ft or 1200m
ISL59605	5300ft or 1600m

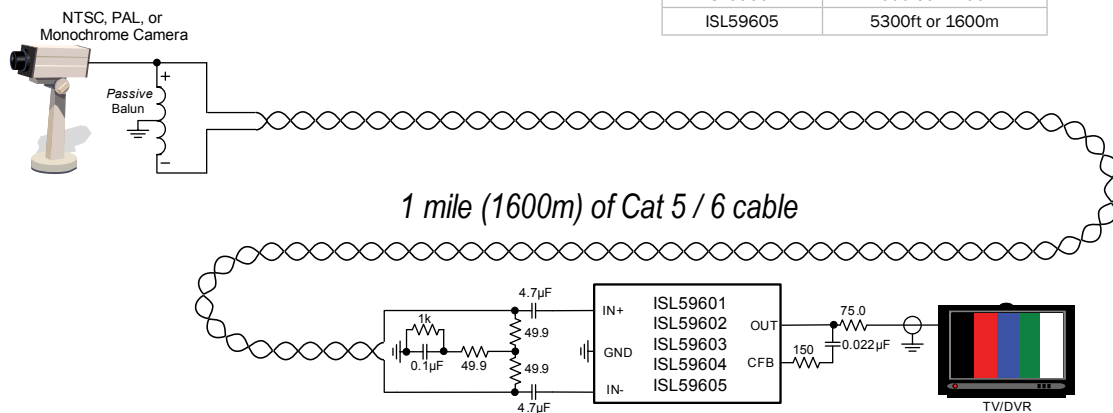

# VIDEO PRODUCTS

## SELECTING VIDEO ICs BY APPLICATION



**Selection Table**  
Composite Video

### EQUALIZERS

Device	Description	Minimum distance for all cables (m or ft)	Maximum distance over Cat 5e (ft)	Maximum distance over Cat 5e (m)	Maximum distance over RG-59 Coax (ft)	Maximum distance over RG-59 Coax (m)	V <sub>s</sub> (V)	Typical I <sub>s</sub> (mA)	Package
ISL59601	Fully Adaptive Composite Video Equalizer	0	1000	300	1700	500	5	76	20 Ld QFN
ISL59602	Fully Adaptive Composite Video Equalizer	0	2000	600	4500	1400	5	79	20 Ld QFN
ISL59603	Fully Adaptive Composite Video Equalizer	0	3000	900	6000	1800	5	82	20 Ld QFN
ISL59604	Fully Adaptive Composite Video Equalizer	0	4000	1200	6000	1800	5	84	20 Ld QFN
ISL59605	Fully Adaptive Composite Video Equalizer	0	5300	1600	6000	1800	5	87	20 Ld QFN

### MULTIPLEXERS

Device	Device Description	Configuration	BW (MHz)	SR (V/μs)	I <sub>s</sub> (mA)	Gain A <sub>v</sub> (min)	I <sub>out</sub> (mA)	Diff Gain (%)	Diff Phase (°)	Package
ISL59420	400MHz Multiplexing Amplifier	2 to 1	420	966	11	1	130	0.01	0.02	10 Ld MSOP
ISL59421	865MHz Multiplexing Amplifier	2 to 1	865	1417	14.5	1	130	0.01	0.02	10 Ld MSOP
ISL59440	400MHz Multiplexing Amplifier	4 to 1	411	1053	14.5	1	130	0.01	0.02	16 Ld QSOP
ISL59441	900MHz Multiplexing Amplifiers	4 to 1	900	1349	17	1	130	0.01	0.02	16 Ld QSOP
ISL59442	1GHz, 4x1 Multiplexing Amplifier	4 to 1	1000	1452	18	1	130	0.01	0.02	14 Ld SOIC
ISL59444	1GHz, 4 x 1 Video Crosspoint Switch with Synchronous Controls	4 to 1	1000	1515	18	1	120	0.01	0.02	16 Ld SOIC
HA4314B	400MHz, 4x1 Video Crosspoint Switch	4 to 1	400	1400	10.5	1	20	0.01	0.01	14 Ld PDIP, 14 Ld SOIC, 16 Ld QSOP
HA4344B	350MHz, 4x1 Video Crosspoint Switch with Synchronous Controls	4 to 1	350	1400	10.5	1	20	0.01	0.01	16 Ld SOIC

### CROSSPOINT SWITCHES

Device	Device Description	Configuration	Input Type	BW (MHz)	SR (V/μs)	I <sub>s</sub> (mA)	Gain A <sub>v</sub> (min)	I <sub>out</sub> (mA)	Diff Gain (%)	Diff Phase (°)	Package
HA456	120MHz, Low Power, 8x8 Video Crosspoint Switch	8x8	Single-Ended	120	200	68	1		0.05	0.05	40 Ld PDIP, 44 Ld MLFP, 44 Ld PLCC
ISL59530	16x16 Video Crosspoint	16x16	Singled-Ended	320	520	140	1 or 2	100	0.025	0.05	72 Ld QFN, 356 Ld BGA
ISL59532	32x32 Video Crosspoint	32x32	Singled-Ended	320	520	600	1 or 2	100	0.025	0.05	356 Ld BGA
ISL59534	32x16 Video Crosspoint	32x16	Singled-Ended	320	520	600	1 or 2	100	0.025	0.05	356 Ld BGA

### DIFFERENTIAL VIDEO DRIVERS

Device	Number of Channels	BW (MHz)	SR (V/μs)	V <sub>s</sub> (min) (V)	V <sub>s</sub> (max) (V)	I <sub>s</sub> (per amp) (mA)	Noise V <sub>n</sub> (nV/√Hz)	V <sub>os</sub> (max) (mV)	I <sub>out</sub> (mA)	V <sub>out</sub> (V)	PSRR (dB)	CMRR (dB)	Gain A <sub>v</sub> (min)	Diff Gain (%)	Diff Phase (°)	Enable	Package
EL5170	1	100	1100	5	10	7.4	30	25	85	6.9	83	84	2	0.1	0.1	Y	8 Ld MSOP, 8 Ld SOIC
EL5171	1	250	800	5	10	8	26	25	90	6.8	84	82	1	0.1	0.5	N	8 Ld SOIC

### DIFFERENTIAL VIDEO RECEIVERS

Device	Number of Channels	BW (MHz)	SR (V/μs)	V <sub>s</sub> (min) (V)	V <sub>s</sub> (max) (V)	I <sub>s</sub> (per amp) (mA)	Noise V <sub>n</sub> (nV/√Hz)	V <sub>os</sub> (max) (mV)	I <sub>out</sub> (mA)	V <sub>out</sub> (V)	PSRR (dB)	CMRR (dB)	Gain A <sub>v</sub> (min)	Diff Gain (%)	Diff Phase (°)	Enable	Package
EL5172	1	250	800	5	10	6	26	25	95	7.5	58	95	1	0.04	0.4	Y	8 Ld MSOP, 8 Ld SOIC

### VIDEO AMPLIFIERS

Device	Number of Channels	BW (MHz)	SR (V/μs)	V <sub>s</sub> (min) (V)	V <sub>s</sub> (max) (V)	I <sub>s</sub> (per amp) (mA)	Noise V <sub>n</sub> (nV/√Hz)	V <sub>os</sub> (max) (mV)	I <sub>out</sub> (mA)	V <sub>out</sub> (V)	PSRR (dB)	CMRR (dB)	Gain A <sub>v</sub> (min)	Diff Gain (%)	Diff Phase (°)	Enable	Package
EL5160	1	200	1700	5	10	0.75	4	5	70	6.8	74	62	1	0.1	0.1	Y	6 Ld SOT-23, 8 Ld SOIC
EL5161	1	200	1700	5	10	0.75	4	5	70	6.8	74	62	1	0.1	0.1	N	5 Ld SOT-23
ISL59112	1	40	85	2.5	3.6	2			40	3.2	63		6	0.02	0.04	N	6 Ld SC-70

### VIDEO FILTERS

Device	Input Channels	Output Channels	-3dB Filter Cut-Off (MHz)	V <sub>s</sub> Range (V)	I <sub>s</sub> (per amp) (mA)	Rail-to-Rail	Gain A <sub>v</sub> (min)	Diff Gain (%)	Diff Phase (°)	Enable	Package
ISL59110	1	1	8	+2.5 to +3.6	2	Y	2	0.1	0.05	Y	6 Ld SC-70
ISL59114	2	3	9	+2.5 to +3.6	1.5	Y	2	0.1	0.5	Y	10 Ld uTQFN
ISL59115	3	3	9	+2.5 to +3.6	1.5	Y	2	0.1	0.5	Y	10 Ld uTQFN
ISL59116	2	3	9	+2.5 to +3.6	1.5	Y	2	0.1	0.5	Y	9 Ld CSP T+R
ISL59117	3	3	9	+2.5 to +3.6	1.5	Y	2	0.1	0.5	Y	9 Ld CSP T+R
ISL59118	2	2	9	+2.5 to +3.6	2.3	Y	2	0.1	0.5	Y	10 Ld QFN T+R

### COMPUTER AND COMPONENT VIDEO

Computers and computer screens are becoming more and more common place, not only in our places of work, but in our everyday lives. They are used to display information from menus in restaurants to schedules in train stations. You will find them delivering advertising messages practically anywhere from supermarkets to elevators. Classrooms are becoming more high-tech, where each student has their own terminal to view the teacher's screen. Many office environments need to display multiple computer video screens without having the actual PC box cluttering up the workspace. As screens get larger, pixel resolution increases, driving the need for higher bandwidth components to support them. These systems are often referred to as KVM, where Keyboard, Video and Mouse signals are transported over cables, to enable the screens and monitors to be located in remote locations, or simply to hide the bulk of the PCs due to space constraints or aesthetic preferences.

**Triple Analog Video Delay Line**

- ISL59920,
- ISL59921,
- ISL59922,
- ISL59923

**NEXT GENERATION DELAY LINES FOR KVM**

Intersil was first to introduce an integrated analog delay line (EL9115) to compensate for the delay between colors when an RGB signals is sent over different pairs of the same Cat 5 cable (each pair has a different physical length as they have different twist ratios). Here we introduce a new family of delay lines that are pin-compatible with the original EL9115. The ISL59920 provides the familiar 62ns of total delay in 2ns increments. The ISL59921 and ISL59922 offer higher bandwidth, enabling support for higher resolution images up to 230MHz. The ISL59923 offers less total delay, while maintaining the 2ns step size, targeting shorter range, lower cost applications, where neither the bandwidth or distance requirements are that high.

The ISL59911 is a new triple-channel equalizer that will be released later in 2010. It increases bandwidth up to 350MHz, and provides the user with much more flexibility in terms of the equalization curve, which is no longer fixed. Instead, each pole can be adjusted through a serial interface, allowing it to be matched to Cat 5, Cat 6 or Cat 7 cables. Please see page 10 for more details.

Part Number	Bandwidth	Total Delay	Step size
ISL59920	153MHz	62ns	2ns
ISL59921	210MHz	46.5ns	1.5ns
ISL59922	230MHz	31ns	1ns
ISL59923	153MHz	30ns	2ns

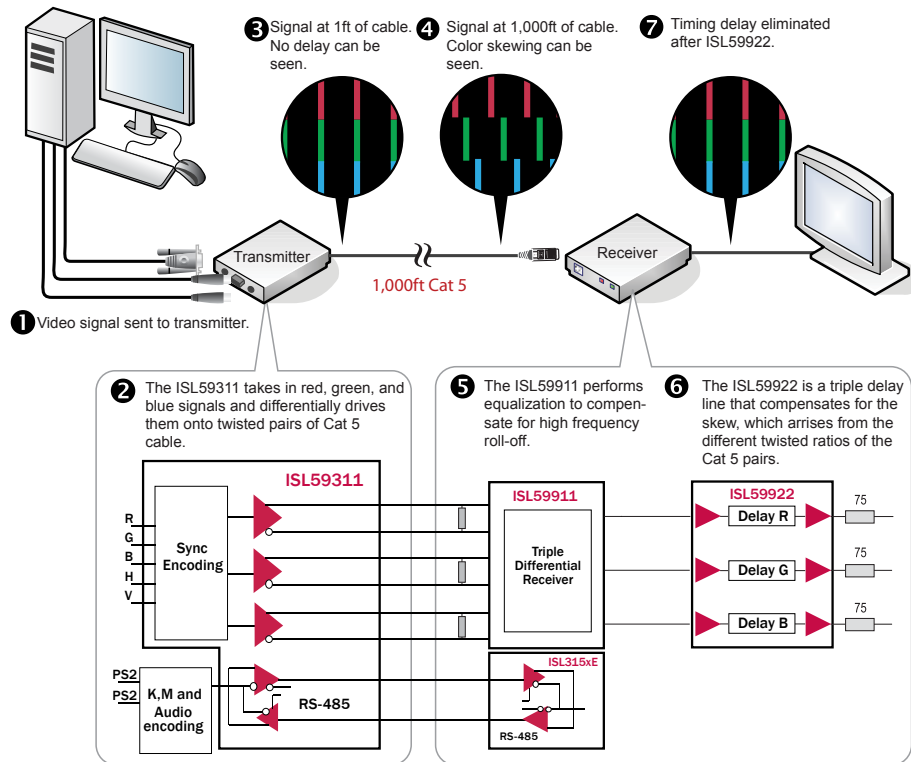



**Selection Table**  
Computer and  
Component Video

**EQUALIZERS**

Device	Number of Channels	SR (V/μs)	V <sub>s</sub> (min) (V)	V <sub>s</sub> (max) (V)	BW (MHz)	Max Equalization (dB)	Gain A <sub>v</sub> (V/V)	I <sub>s</sub> (per amp) (mA)	I <sub>out</sub> (mA)	V <sub>out</sub> (V)	V <sub>os</sub> (max) (mV)	CMRR (dB)	PSRR (dB)	Package
EL9110	1	1500	±5	±6	150	60	1 or 2	33	60	±3.5	250	60	60	16 Ld QSOP
EL9111	3	1500	±5	±6	150	45	1 or 2	36	60	±3.5	78	80	65	28 Ld QFN
EL9112	3	1500	±5	±6	150	45	1 or 2	36	60	±3.5	78	80	65	28 Ld QFN
ISL59910	3	1500	±5	±5	150	45	1 or 2	36	60	±3.5	110	80	65	28 Ld QFN
ISL59913	3	1500	±5	±5	150	45	1 or 2	36	60	±3.5	110	80	65	28 Ld QFN

Device	Description	BW (MHz)	EQ Range @ 100MHz (dB)	EQ Range @ 20MHz (dB)	EQ Range @ 6MHz (dB)	EQ Range @ 1MHz (dB)	EQ Range @ 200kHz (dB)	Min LPF Corner (MHz)	Max LPF Corner (MHz)	Nominal Supply (V)	Typical I <sub>s</sub> (mA)	Package
ISL59911 (Coming soon)	Triple Differential Receiver/ Equalizer with I2C Control	350	68	35	16	6.0	1.4	50	600	±5V	105	32 Ld QFN

**DELAY LINES**

Device	Number of Channels	SR (V/μs)	V <sub>s</sub> (min) (V)	V <sub>s</sub> (max) (V)	BW (MHz)	Delay Increment (ns)	Max Delay (ns)	Gain A <sub>v</sub> (min)	I <sub>s</sub> (mA)	I <sub>out</sub> (mA)	PSRR (dB)	Package
ISL59920	3	550	±4	±6	153	2	62	1 or 2	115	53	58	20 Ld QFN
ISL59921	3	640	±4	±6	200	1.5	46.5	1 or 2	125	53	58	20 Ld QFN
ISL59922	3	700	±4	±6	230	1	31	1 or 2	125	53	58	20 Ld QFN
ISL59923	3	550	±4	±6	153	2	30	1 or 2	90	53	58	20 Ld QFN
EL9115	3	400	±5	±6	122	2	62	2	87	30	53	20 Ld QFN

**VIDEO DRIVERS WITH SYNC ENCODING**

Device	Number of Channels	BW (MHz)	SR (V/μs)	V <sub>s</sub> (min) (V)	V <sub>s</sub> (max) (V)	I <sub>s</sub> (per amp) (mA)	Noise V <sub>n</sub> (nV/√Hz)	V <sub>os</sub> (max) (mV)	I <sub>out</sub> (mA)	V <sub>out</sub> (V)	PSRR (dB)	CMRR (dB)	Gain A <sub>v</sub> (min)	Diff Gain (%)	Diff Phase (°)	Enable	Package
ISL59311	3	650	1500	4.5	5.5	17	15	1	60	4.4	75	75	2	0.01	0.01	Y	32 Ld QFN
EL4543	3	350	1200	5	12	14.5	27	10	60		80	80	2	0.01	0.01	Y	20 Ld QFN, 24 Ld QSOP

**DIFFERENTIAL VIDEO DRIVERS**

Device	Number of Channels	BW (MHz)	SR (V/μs)	V <sub>s</sub> (min) (V)	V <sub>s</sub> (max) (V)	I <sub>s</sub> (per amp) (mA)	Noise V <sub>n</sub> (nV/√Hz)	V <sub>os</sub> (max) (mV)	I <sub>out</sub> (mA)	V <sub>out</sub> (V)	PSRR (dB)	CMRR (dB)	Gain A <sub>v</sub> (min)	Diff Gain (%)	Diff Phase (°)	Enable	Package
EL5370	3	100	1100	5	10	7	30	25	85	6.9	83	84	2	0.1	0.1	Y	24 Ld QSOP
EL5371	3	250	800	5	10	8	26	25	90	6.8	84	82	1	0.1	0.5	N	28 Ld QSOP
EL5373	3	450	1100	4.75	11	12	25	30	55	7.7	73	80	2	0.06	0.13	Y	24 Ld QSOP
EL5374	3	550	1100	4.75	11	12.5	21	25	60	7.6	75	78	1	0.06	0.13	Y	28 Ld QSOP
EL5378	3	700	1000	4.75	11	12.5	18	30	60	7.4	75	78	2	0.06	0.13	Y	28 Ld QSOP

**DIFFERENTIAL VIDEO RECEIVERS**

Device	Number of Channels	BW (MHz)	SR (V/μs)	V <sub>s</sub> (min) (V)	V <sub>s</sub> (max) (V)	I <sub>s</sub> (per amp) (mA)	Noise V <sub>n</sub> (nV/√Hz)	V <sub>os</sub> (max) (mV)	I <sub>out</sub> (mA)	V <sub>out</sub> (V)	PSRR (dB)	CMRR (dB)	Gain A <sub>v</sub> (min)	Diff Gain (%)	Diff Phase (°)	Enable	Package
EL5372	3	250	800	5	10	6	26	25	95	7.5	58	95	1	0.04	0.4	Y	24 Ld QSOP
EL5375	3	550	900	4.75	11	9.6	21	30	67	7.49	56	95	1	0.1	0.1	Y	24 Ld QSOP

**CROSSPOINT SWITCHES**

Device	Configuration	Input Type	BW (MHz)	SR (V/μs)	I <sub>s</sub> (mA)	Gain A <sub>v</sub> (min)	I <sub>out</sub> (mA)	Diff Gain (%)	Diff Phase (°)	Package
EL4544	Triple 16x4	Differential	300	1000	400	1 to 4	60	0.05	0.05	356 Ld BGA

**MULTIPLEXERS**

Device	Configuration	BW (MHz)	SR (V/μs)	I <sub>s</sub> (mA)	Gain A <sub>v</sub> (min)	I <sub>out</sub> (mA)	Diff Gain (%)	Diff Phase (°)	Package
EL4340	Triple 2 to 1	500	870	30	1	135	0.02	0.02	24 Ld QSOP
EL4342	Triple 4 to 1	500	870	46	1	135	0.02	0.02	32 Ld QFN
ISL59446	Triple 4 to 1	500	1600	46	2	135	0.02	0.02	32 Ld QFN
ISL59448	Triple 2 to 1	500	1600	30	2	135	0.02	0.02	24 Ld QSOP
ISL59424	Triple 2 to 1	1000	1200	39	1	130	0.02	0.02	24 Ld QFN
ISL59445	Triple 4 to 1	1000	1200	53	1	130	0.02	0.02	32 Ld QFN
ISL59481	Dual, Triple 4 to 1	500	870	92	1	135	0.02	0.02	48 Ld QFN
ISL59482	Dual, Triple 4 to 1	500	1600	16	2	135	0.01	0.04	48 Ld QFN
ISL59483	Dual, Triple 4 to 1	500	1600	92	1	125	0.02	0.02	48 Ld QFN

**VIDEO FILTERS**

Device	Input Channels	Output Channels	-3dB Filter Cut-Off (MHz)	V <sub>s</sub> Range (V)	I <sub>s</sub> (per amp) (mA)	Rail-to-Rail	Gain A <sub>v</sub> (min)	Diff Gain (%)	Diff Phase (°)	Enable	Package
ISL59114	2	3	9	+2.5 to +3.6	1.5	Y	2	0.1	0.5	Y	10 Ld uTQFN
ISL59115	3	3	9	+2.5 to +3.6	1.5	Y	2	0.1	0.5	Y	10 Ld uTQFN
ISL59116	2	3	9	+2.5 to +3.6	1.5	Y	2	0.1	0.5	Y	9 Ld CSP T+R
ISL59117	3	3	9	+2.5 to +3.6	1.5	Y	2	0.1	0.5	Y	9 Ld CSP T+R
ISL59123	3	3	18	+2.5 to +3.6	1.3	Y	2	0.1	0.5	Y	9 Ld WLCSP

**VIDEO AMPLIFIERS**

Device	Number of Channels	BW (MHz)	SR (V/μs)	V <sub>s</sub> (min) (V)	V <sub>s</sub> (max) (V)	I <sub>s</sub> (per amp) (mA)	Noise V <sub>n</sub> (nV/√Hz)	V <sub>os</sub> (max) (mV)	I <sub>out</sub> (mA)	V <sub>out</sub> (V)	PSRR (dB)	CMRR (dB)	Gain A <sub>v</sub> (min)	Diff Gain (%)	Diff Phase (°)	Enable	Package
EL5360	3	200	1700	5	10	0.75	4	5	70	6.8	74	62	1	0.1	0.1	Y	16 Ld QSOP, 16 Ld SOIC
EL5304	3	700	7000	5	10	9.5	10	10	160	7.6	70	62	1	0.01	0.01	Y	16 Ld QSOP
ISL59833	3	200	500	3	3.6	32.3	20	25	50	5.1	68		2	0.07	0.06	Y	16 Ld QSOP
ISL59837	3	200	500	3	3.6	32.3	20	25	50	5.1	62		2	0.07	0.06	Y	16 Ld QSOP

### DIGITAL VIDEO

First DVI, then HDMI and now DisplayPort are all making their mark on the video landscape, each finding their own place in the market. Now applications are demanding that these signals be switched and transmitted over longer distances than they were designed for. Here you will find equalizers, regenerators and multiplexers for TMDS signals. We are also introducing an active cable for DisplayPort which enables high-speed signals to be sent over a narrow gauge twinax cable, replacing bulky and expensive fiber.

**DisplayPort  
QLX4270-DP**

**STANDARD- TO MINI-DISPLAYPORT ACTIVE COPPER  
TWINAX CABLE**

Intersil's Standard- to Mini-DisplayPort Active Copper Cable is an active copper cable assembly. The cables are compliant with the current DisplayPort 1.1 specification, while also supporting the 5.4 Gbps serial data rate specified in DisplayPort 1.2. They provide connectivity between devices using the mini-DisplayPort connector and those using standard DisplayPort connector. Intersil's revolutionary Q:Active® analog signal processing technology enables ultra-thin as well as extended-reach copper cables that far surpass the capabilities of passive copper cables. With no software or drivers to install, the Standard- to Mini-DisplayPort Active Copper Cables are plug-and-play high-performance interconnects serving high-definition display needs from desktop, gaming, and home theater in the living room to largest commercial installations.

Part Number	Twinax Cable Length and Gauge
QLX4270CSMDP0540	5 meters, 40AWG
QLX4270CSMDP1036	10 meters, 36AWG
QLX4270CSMDP1532	15 meters, 32AWG
QLX4270CSMDP2032	20 meters, 32AWG

**KEY FEATURES**

- Full Bandwidth DisplayPort
- Lengths up to 20m (passive cables are limited to ~3m)
- Delivers accurate, brilliant pure digital color performance
- 2560 x 1600p display resolution at 60/120Hz with full digital audio
- Supports ultra-thin, long-reach twinax cable
- Features Q:Active® Analog Signal Processing technology

**BENEFITS**

- Display source can be located up to 20m away from monitors
- Ultra-thin, lightweight copper interconnect (32 - 40 AWG twinax cable)
- Lower cost, lower power and more reliable than repeaters or optics

**APPLICATIONS**

- Professional Studios, Exhibits, Public Display Venues, Sports Bars, Stadiums
- Entertainment, Extreme Gaming, Multi-Monitor Control Room Applications

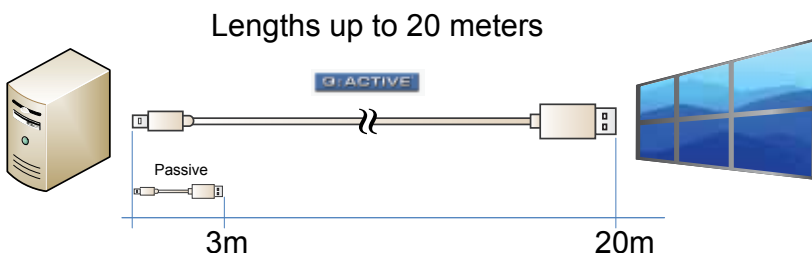

**About Q:Active®**

By integrating its analog ICs inside cabling interconnects, Intersil is able to achieve unsurpassed improvements in reach, power consumption, latency, and cable gauge size as well as increased airflow. This new technology transforms passive cabling into intelligent "roadway" that yield lower operating expenses and capital expenditures for the expanding interconnect market.



# VIDEO PRODUCTS

## SELECTING VIDEO ICs BY APPLICATION



**TMDS Mux/  
Equalizer  
ISL54100**

**THE INDUSTRY'S ONLY DVI / HDMI™ MUXES WITH CDR FOR JITTER REMOVAL**

Anybody's TMDS mux/equalizer can restore some of the signal quality lost in long cables with a bit of equalization, but only Intersil's ISL54100/01/02 feature Clock Data Recovery on each channel to regenerate an output signal as pristine and jitter-free as it was at the source.

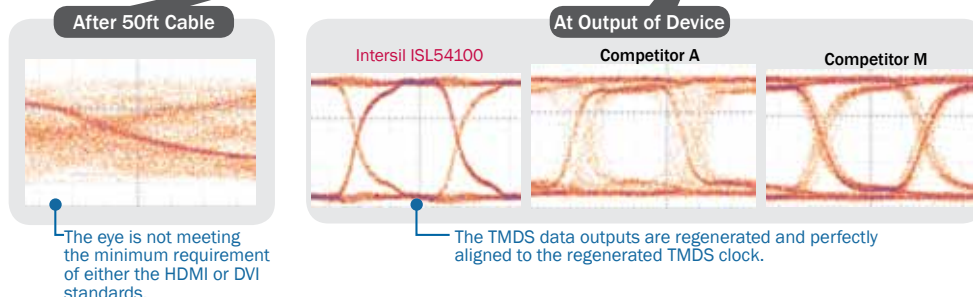
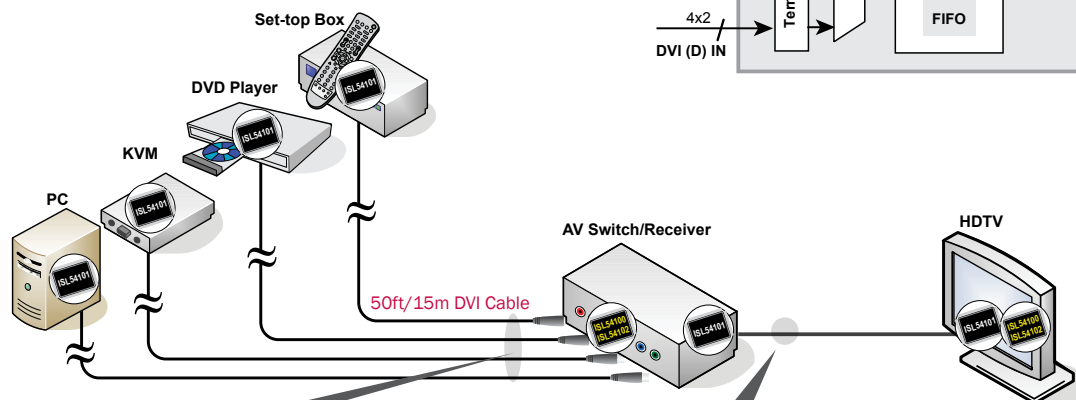
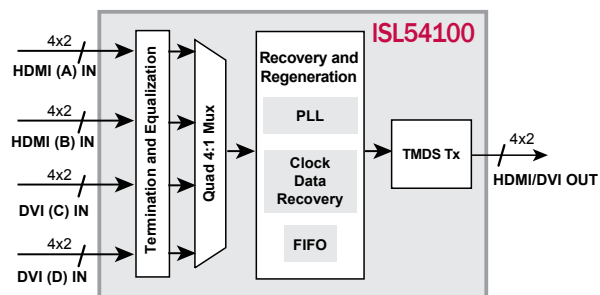

**Selection Table  
Digital Video**

**TMDS REGENERATOR WITH EQ (HDMI/DVI)**

Device	Device Description	# of Channels	Programmable Pre-Emphasis	Programmable Equalization	Topology	Internal Input Termination (Ω)	Maximum Pixel Rate (MHz)	V <sub>s</sub> (V)	Package
ISL54101A	TMDS Regenerator	1	Y	Y	TMDS Regenerator	50, 100 or Disconnected	165	3.3	128 Ld MQFP
ISL54105A	TMDS Regenerator	1	Y	Y	TMDS Regenerator	50, 100 or Disconnected	165	3.3	72 Ld QFN

**TMDS MULTIPLEXERS WITH REGENERATION (HDMI/DVI)**

Device	Device Description	# of Channels	Programmable Pre-Emphasis	Programmable Equalization	Topology	Internal Input Termination (Ω)	Maximum Pixel Rate (MHz)	V <sub>s</sub> (V)	Package
ISL54100A	TMDS Regenerators with Multiplexers	4	Y	Y	TMDS Regenerator plus MUX	50, 100 or Disconnected	165	3.3	128 Ld MQFP
ISL54102A	TMDS Regenerators with Multiplexers	2	Y	Y	TMDS Regenerator plus MUX	50, 100 or Disconnected	165	3.3	128 Ld MQFP

**DDC ACCELERATOR**

Device	Device Description	V <sub>TRIPL</sub> (V)	V <sub>TRIPH</sub> (V)	Standby Pull-Up Current (μA)	Active Pull-Up Current (μA)	Boost Pull-Up Current (mA)	V <sub>s</sub> (V)	Package
ISL54103	DDC Accelerator (DDCA)	0.75	VDD-0.50	80	275	2.2	2.7 to 5.5	5 Ld SOT-23

**DISPLAY PORT**

Device	Device Description	Max Data Rate (Gb/s)	Channels	Power (mW)	V <sub>s</sub> (V)	Package
QLX4270-DP	DisplayPort Lane Extender	5.4	4	312	1.2	46 Ld QFN

### CABLE COMPENSATION

Intersil is an industry leader in cable compensation. Whether it is the new MegaQ technology enabling composite video to be recovered from 1 mile of cable or whether you are working with digital video standards such as Display Port and HDMI, Intersil has a cable compensation solution for you. Here you will find cable drivers, cable equalizers and delay lines to correct for timing issues incurred when using certain types of cables.

**Equalizer  
ISL59911**

**TRIPLE DIFFERENTIAL RECEIVER/ EQUALIZER WITH I<sup>2</sup>C CONTROL**

The ISL59911 is a new high bandwidth triple-channel equalizer for the KVM (Keyboard, Video, Mouse) application space. This is our 4th generation of equalizers for RGB signals, providing a bandwidth of 350MHz and enabling much higher resolution images to be recovered from a Cat X cable. The ISL59911 introduces a new approach to equalization. Previous generations of equalizers have had a fixed equalization curve, which was optimized for Cat 5 cable. Cat 6 and Cat 7 are becoming increasingly popular cables in this market space and present slightly different equalization needs, as well as the challenges introduced by

different gauge wires. The ISL59911 has a serial interface which allows users to adjust the compensation network via software, enabling the overall curves to be optimized for different cable characteristics. The ISL59911 is currently sampling and will release at the end of 2010.

**KEY FEATURES**

- 350MHz - 3dB bandwidth
- 5 Adjustable EQ bands: 100MHz, 20MHz, 6MHz, 1MHz, and 200kHz
- 3rd-order lowpass filter at output with programmable corner
- 7 bit, ±4dB PGA for DC gain control
- 105mA supply current with ±5V supplies

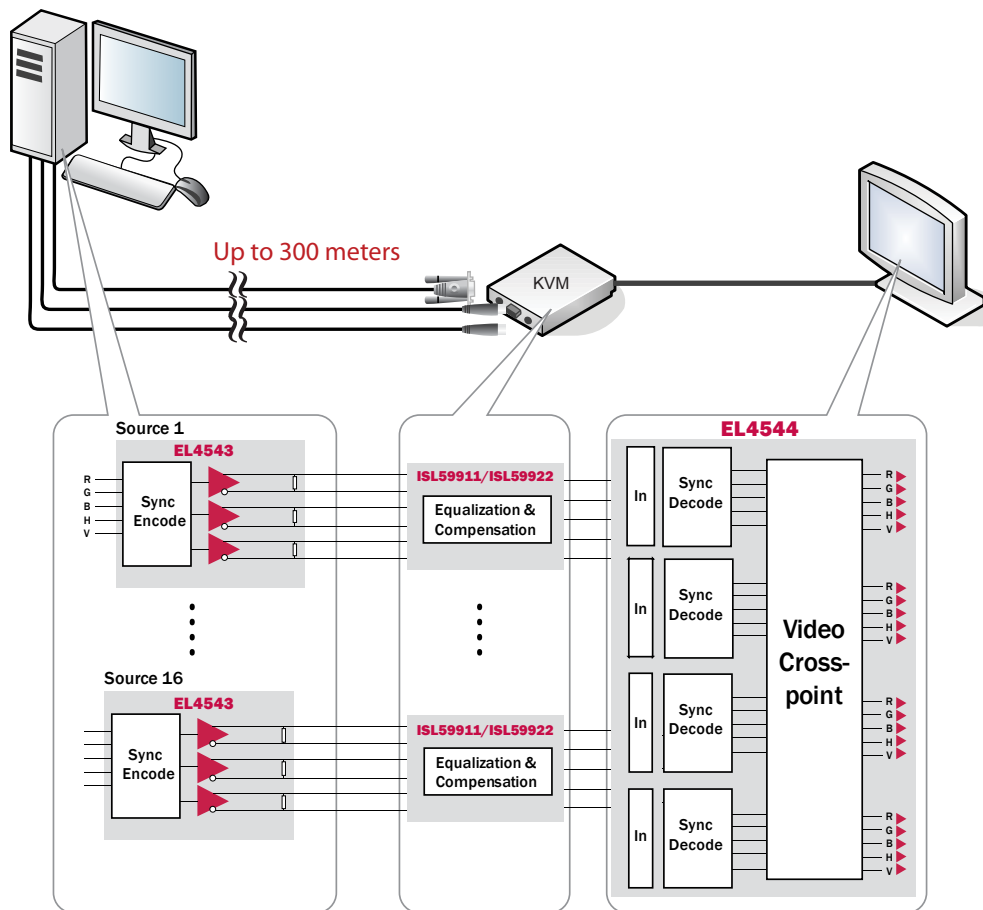

# VIDEO PRODUCTS

## SELECTING VIDEO ICs BY FUNCTION



**Selection Table**  
Cable  
Compensation

### VIDEO EQUALIZERS

#### COMPOSITE VIDEO

Device	Description	Minimum distance for all cables (m or ft)	Maximum distance over Cat 5e (ft)	Maximum distance over Cat 5e (m)	Maximum distance over RG-59 Coax (ft)	Maximum distance over RG-59 Coax (m)	V <sub>s</sub> (V)	Typical I <sub>s</sub> (mA)	Package
ISL59601	Fully Adaptive Composite Video Equalizer	0	1000	300	1700	500	5	76	20 Ld QFN
ISL59602	Fully Adaptive Composite Video Equalizer	0	2000	600	4500	1400	5	79	20 Ld QFN
ISL59603	Fully Adaptive Composite Video Equalizer	0	3000	900	6000	1800	5	82	20 Ld QFN
ISL59604	Fully Adaptive Composite Video Equalizer	0	4000	1200	6000	1800	5	84	20 Ld QFN
ISL59605	Fully Adaptive Composite Video Equalizer	0	5300	1600	6000	1800	5	87	20 Ld QFN

#### COMPUTER AND COMPONENT VIDEO

Device	Number of Channels	SR (V/μs)	V <sub>s</sub> (min) (V)	V <sub>s</sub> (max) (V)	BW (MHz)	Max Equalization (dB)	Gain A <sub>v</sub> (V/V)	I <sub>BIAS</sub> (μA)	I <sub>OUT</sub> (mA)	V <sub>OUT</sub> (V)	V <sub>OS</sub> (max) (mV)	CMRR (dB)	PSRR (dB)	Package
EL9110	1	1500	10	12	150	60	1 or 2	1	60	7	250	60	60	16 Ld QSOP
EL9111	3	1500	±5	±6	150	45	1 or 2	1	60	±3.5	78	80	65	28 Ld QFN
EL9112	3	1500	±5	±6	150	45	1 or 2	1	60	±3.5	78	80	65	Eval Board, 28 Ld QFN
ISL59910	3	1500	±5	±5	150	45	1 or 2	1	60	±3.5	110	80	65	28 Ld QFN
ISL59913	3	1500	±5	±5	150	45	1 or 2	1	60	±3.5	110	80	65	28 Ld QFN

Device	Description	BW (MHz)	EQ Range @ 100MHz (dB)	EQ Range @ 20MHz (dB)	EQ Range @ 6MHz (dB)	EQ Range @ 1MHz (dB)	EQ Range @ 200kHz (dB)	Min LPF Corner (MHz)	Max LPF Corner (MHz)	Nominal Supply (V)	Typical I <sub>s</sub> (mA)	Package
ISL59911	Triple Differential Receiver/ Equalizer with I <sup>2</sup> C Control	250	68	35	16	6.0	1.4	50	600	±5V	105	32 Ld QFN

#### TDMS EQUALIZERS WITH REGENERATION

Device	# of Channels	Programmable Pre-Emphasis	Programmable Equalization	Topology	Internal Input Termination (Ω)	Maximum Pixel Rate (MHz)	V <sub>s</sub> (V)	Package
ISL54101A	1	Y	Y	TMDS Regenerator	50, 100 or Disconnected	165	3.3	128 Ld MQFP
ISL54105A	1	Y	Y	TMDS Regenerator	50, 100 or Disconnected	165	3.3	72 Ld QFN

### SKEW COMPENSATION

#### COMPUTER AND COMPONENT VIDEO

Device	Number of Channels	SR (V/μs)	V <sub>s</sub> (min) (V)	V <sub>s</sub> (max) (V)	BW (MHz)	Delay Increment (ns)	Max Delay (ns)	Gain A <sub>v</sub> (min)	I <sub>s</sub> (mA)	I <sub>BIAS</sub> (μA)	I <sub>OUT</sub> (mA)	PSRR (dB)	Package
ISL59920	3	550	±4	±6	153	2	62	1 or 2	115	6	53	58	20 Ld QFN
ISL59921	3	640	±4	±6	200	1.5	46.5	1 or 2	125	6	53	58	20 Ld QFN
ISL59922	3	700	±4	±6	230	1	31	1 or 2	125	6	53	58	20 Ld QFN
ISL59923	3	550	±4	±6	153	2	30	1 or 2	90	6	53	58	20 Ld QFN
EL9115	3	400	±5	±6	122	2	62	2	87	1	30	53	20 Ld QFN

### SIGNAL SWITCHING

Intersil offers a wide range of switching solutions covering analog video signals from composite video to the highest-resolution RGB graphics. Whether you are looking for a simple 2:1 mux or a large 32 x 32 crosspoint switch, you will find the highest-bandwidth and most-integrated solutions here.

Our TMDS multiplexers are perfect for HDMI and DVI signals and provide much more than just switching. Each multiplexer eliminates jitter from the TMDS signals using integrated CDR (Clock Data Recovery) and equalizer, which completely regenerate the signals, compensating for signal loss from transmission over long cables or simply through connectors and PCB traces.

**Video Crosspoint**  
**ISL59532**

#### 300MHz 32x32 VIDEO CROSSPOINT SWITCH

This 300MHz, 32x32 crosspoint switch features great video performance with 0.025% differential gain and 0.05° differential phase along with 0.1dB flatness out to 50MHz. It is a non-blocking switch, so any combination of inputs can be sent to any combination of outputs. There is also a Broadcast mode, which sends one input to all outputs by simply programming one register.

#### KEY FEATURES

- Excellent Video performance
  - 300MHz of Bandwidth
  - Superb crosstalk of -90dB at 6MHz
  - Excellent Diff gain and Phase 0.01%/0.03°
- Easy to use
  - All switching combinations are possible.
  - Broadcast mode provides 1:32 fan out
  - SPI interface
  - Select gain
  - Program crosspoint
  - Tri-Statable outputs
- High level of integration
  - 356Ld BGA package
  - Equivalent to 4 16x16 crosspoints!!
  - DC-restore option on all channels
  - OSD switch for each channel

#### INTEGRATE FOUR 16x16s INTO ONE 32X32

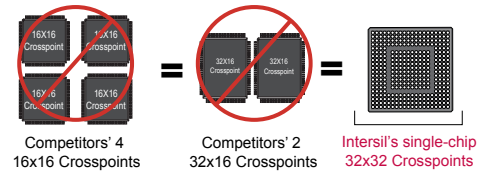

#### INDUSTRY'S SMALLEST 16x16 VIDEO CROSSPOINT (ISL59530)

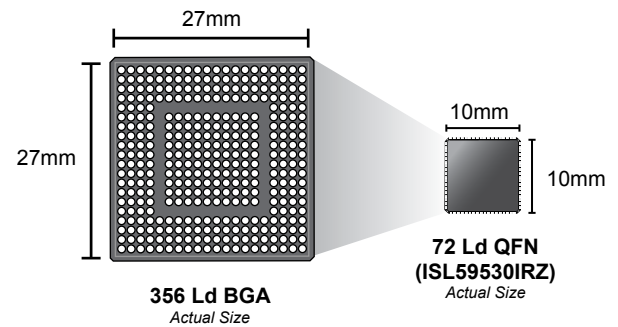

#### Integrated DC-restore (Clamp) on Every Input

Ensure the video is at the correct level. Reduces BOM and board space.

#### Fast OSD Switch on Each Channel

Insert text onto the video. Eliminates extra silicon around device.

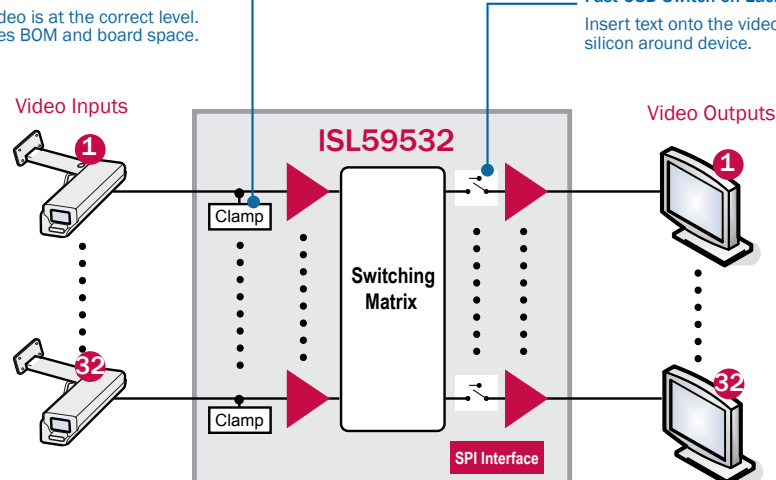

# VIDEO PRODUCTS

## SELECTING VIDEO ICs BY FUNCTION



**Selection Table**  
Video Switching

### MULTIPLEXERS

#### SINGLE CHANNEL

Device	Configuration	BW (MHz)	SR (V/ $\mu$ s)	I <sub>s</sub> (mA)	Gain A <sub>v</sub> (min)	I <sub>out</sub> (mA)	Diff Gain (%)	Diff Phase (°)	Package
ISL59420	2 to 1	420	966	11	1	130	0.01	0.02	10 Ld MSOP
ISL59421	2 to 1	865	1417	14.5	1	130	0.01	0.02	10 Ld MSOP
ISL59440	4 to 1	411	1053	14.5	1	130	0.01	0.02	16 Ld QSOP
ISL59441	4 to 1	900	1349	17	1	130	0.01	0.02	16 Ld QSOP
ISL59442	4 to 1	1000	1452	18	1	130	0.01	0.02	14 Ld SOIC
ISL59444	4 to 1	1000	1515	18	1	120	0.01	0.02	16 Ld SOIC
HA4314B	4 to 1	400	1400	10.5	1	20	0.01	0.01	14 Ld PDIP, 14 Ld SOIC, 16 Ld QSOP
HA4344B	4 to 1	350	1400	10.5	1	20	0.01	0.01	16 Ld SOIC

#### TRIPLE CHANNEL

Device	Configuration	BW (MHz)	SR (V/ $\mu$ s)	I <sub>s</sub> (mA)	Gain A <sub>v</sub> (min)	I <sub>out</sub> (mA)	Diff Gain (%)	Diff Phase (°)	Package
EL4340	Triple 2 to 1	500	870	30	1	135	0.02	0.02	24 Ld QSOP
EL4342	Triple 4 to 1	500	870	46	1	135	0.02	0.02	32 Ld QFN
ISL59446	Triple 4 to 1	500	1600	46	2	135	0.02	0.02	32 Ld QFN
ISL59448	Triple 2 to 1	500	1600	30	2	135	0.02	0.02	24 Ld QSOP
ISL59424	Triple 2 to 1	1000	1200	39	1	130	0.02	0.02	24 Ld QFN
ISL59445	Triple 4 to 1	1000	1200	53	1	130	0.02	0.02	32 Ld QFN
ISL59481	Dual, Triple 4 to 1	500	870	92	1	135	0.02	0.02	48 Ld QFN
ISL59482	Dual, Triple 4 to 1	500	1600	16	2	135	0.01	0.04	48 Ld QFN
ISL59483	Dual, Triple 4 to 1	500	1600	92	1	125	0.02	0.02	48 Ld QFN

### DVI/HDMI

Device	Device Description	# of Channels	Programmable Pre-Emphasis	Programmable Equalization	Topology	Internal Input Termination ( $\Omega$ )	Maximum Pixel Rate (MHz)	V <sub>s</sub> (V)	Package
ISL54100A	TMDS Regenerators with Multiplexers	4	Y	Y	TMDS Regenerator plus MUX	50, 100 or Disconnected	165	3.3	128 Ld MQFP
ISL54102A	TMDS Regenerators with Multiplexers	2	Y	Y	TMDS Regenerator plus MUX	50, 100 or Disconnected	165	3.3	128 Ld MQFP

### CROSSPOINT SWITCHES

Device	Configuration	Input Type	BW (MHz)	SR (V/ $\mu$ s)	I <sub>s</sub> (mA)	Gain A <sub>v</sub> (min)	I <sub>out</sub> (mA)	Diff Gain (%)	Diff Phase (°)	Package
HA456	8x8	Single-Ended	120	200	68	1		0.05	0.05	44 Ld PLCC
ISL59530	16x16	Singled-Ended	320	520	140	1 or 2	100	0.025	0.05	356 Ld BGA, 72 Ld QFN
ISL59532	32x32	Singled-Ended	300	520	600	1 or 2	100	0.025	0.05	356 Ld BGA
ISL59534	32x16	Singled-Ended	320	520	600	1 or 2	100	0.025	0.05	356 Ld BGA
EL4544	Triple 16x4	Differential	300	1000	400	1 to 4	60	0.05	0.05	356 Ld BGA

### DATA CONVERSION

The following products digitize RGB (PC video) or YPbPr (component video) signals and combine industry-leading specifications with extreme ease of use parts, while adding many automatic functions that are unique to Intersil.

If you are interested in Composite Video Decoders, take a look at our new product range from Techwell at [www.techwellinc.com](http://www.techwellinc.com)

**10-bit Analog Front End**  
**ISL51002**

**10-BIT VIDEO DIGITIZER WITH MEASUREMENT AND AUTO-ADJUST FEATURES**

Intersil's ISL51002 delivers true 10-bit performance at a 165MSPS maximum conversion rate, supporting resolutions up to 1080p/UXGA at 60Hz, as well as all the other features and benefits of the ISL98003 (below).

**8-bit Analog Front End**  
**ISL98003**

**8-BIT ANALOG FRONT END (AFE) WITH MEASUREMENT & AUTO-ADJUST FEATURES**

The ISL98003 is a breakthrough in the digitizing of analog RGB and component video. It combines remarkable channel linearity, automatic independent channel offset adjustment, an innovative digital PLL, a fully Macrovision™-compliant sync separator with sync parameter measurement and automatic sampling phase adjustment. All of this creates the easiest to use video digitizing solution available.

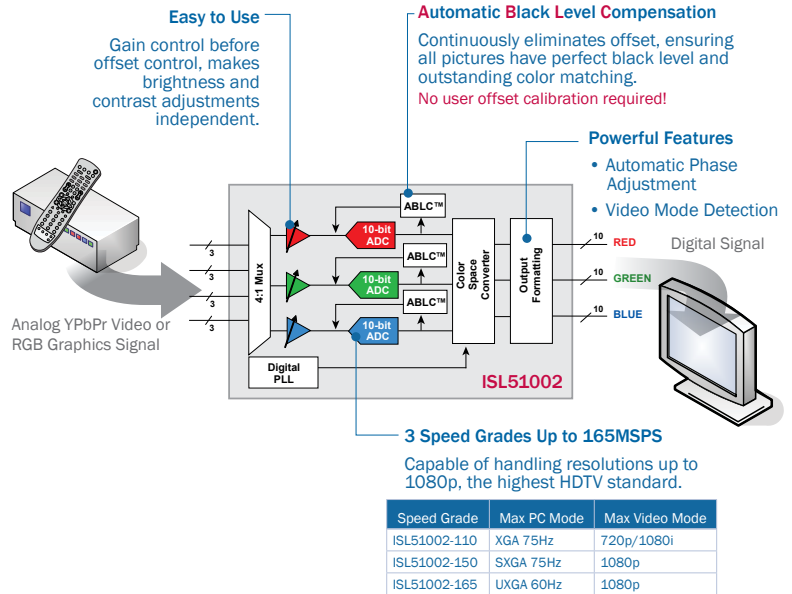

**KEY FEATURES**

- Upconverts Analog Video to Digital
- Measures incoming sync signal timing
- Generates DE signal for DVI transmitters
- Automatically finds optimum sampling phase in less than 1 second with no assistance from µC

**INTERSIL AFEs ARE AUTOMATIC**

- Automatic Sync Source Selection
- Automatic Macrovision Compatibility
- Automatic Black Level Compensation
- Automatic Phase adjustment
- Automatic DPLL compensation
- Automatic DE Generation

**REFERENCE DESIGN FOR CONVERTING RGB VIDEO TO DVI**

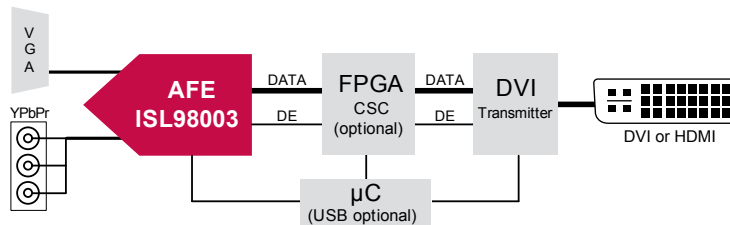



# VIDEO PRODUCTS

## SELECTING VIDEO ICs BY FUNCTION



**Selection Table**  
Data Conversion

**AFE**  
**8 BITS**

Device	Device Description	Resolution (Bits)	Max Conversion Rate (MSPS)	Typical PLL Jitter (ps) (p-p)	Sync Measurement	Auto Phase Adjust	Typical Power Dissipation @ Max Conversion Rate (mW)	Package
ISL98001-140	Advanced 140MHz Triple Video Digitizer with Digital PLL	8	140	250	N	N	950	128 Ld MQFP
ISL98001-170	Advanced 170MHz Triple Video Digitizer with Digital PLL	8	170	250	N	N	1050	128 Ld MQFP
ISL98001-210	Advanced 210MHz Triple Video Digitizer with Digital PLL	8	210	250	N	N	1100	128 Ld MQFP
ISL98001-275	Advanced 275MHz Triple Video Digitizer with Digital PLL	8	275	250	N	N	1200	128 Ld MQFP
ISL98002-140	Triple Video Digitizer with Digital PLL	8	140	250	N	N	535	72 Ld QFN
ISL98002-170	Triple Video Digitizer with Digital PLL	8	170	250	N	N	535	72 Ld QFN
ISL98003-110	8-Bit Video Analog Front End (AFE) with Measurement and Auto-Adjust Features	8	110	250	Y	Y	940	80 Ld EPTQFP
ISL98003-150	8-Bit Video Analog Front End (AFE) with Measurement and Auto-Adjust Features	8	150	250	Y	Y	970	80 Ld EPTQFP
ISL98003-165	8-Bit Video Analog Front End (AFE) with Measurement and Auto-Adjust Features	8	165	250	Y	Y	980	80 Ld EPTQFP

**10 BITS**

Device	Device Description	Resolution (Bits)	Max Conversion Rate (MSPS)	Typical PLL Jitter (ps) (p-p)	Sync Measurement	Auto Phase Adjust	Typical Power Dissipation @ Max Conversion Rate (mW)	Package
ISL51002-110	10-Bit Video Analog Front End (AFE) with Measurement and Auto-Adjust Features	10	110	250	Y	Y	940	128 Ld MQFP
ISL51002-150	10-Bit Video Analog Front End (AFE) with Measurement and Auto-Adjust Features	10	150	250	Y	Y	970	128 Ld MQFP
ISL51002-165	10-Bit Video Analog Front End (AFE) with Measurement and Auto-Adjust Features	10	165	250	Y	Y	980	128 Ld MQFP

### BUILDING BLOCKS

Video systems are extremely diverse, displaying a huge range of resolutions and formats, with varying amounts of signal-processing required. In many cases, building blocks are needed to support a function in a larger system. Many simple blocks can work together. Here you will find our range of video building blocks suited for a wide range of video applications.

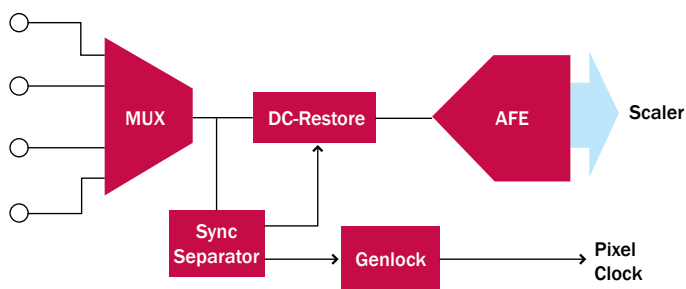

#### Video Sync Separator ISL59885

#### AUTO-ADJUSTING SYNC SEPARATOR

The ISL59885 is the only sync separator solution on the market that does not require any external components to select a particular frequency. The ISL59885 removes all of these discretes (up to 30 components) and needs no user intervention to work over a wide range of video standards.

#### KEY FEATURES

- Handles SD and HD signals from CVBS up to 1080p
- External capacitor auto-sets timing for all relevant standards
  - Unique architecture makes timing independent of temperature
- HD indicator allows for more downstream functionality to be switched in, saving power
  - > 480p inputs flagged as HD
- Hsync output eases genlocking requirements
- Standard S0 package

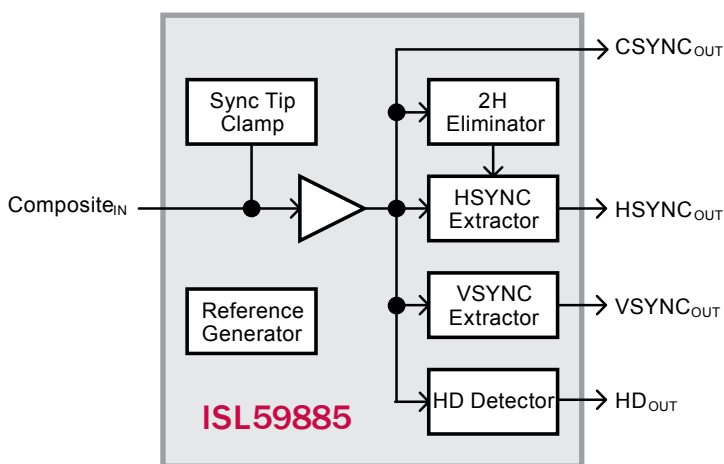

# VIDEO PRODUCTS

## SELECTING VIDEO ICs BY FUNCTION



### Selection Table

#### Video Building Blocks

#### SYNC SEPARATORS

Device	Slicing Fixed (70mV)	Slicing Input Adaptive	Color Burst Filter (Internal)	Color Burst Filter (External)	Outputs Composite	Outputs Horizontal	Outputs Vertical	Outputs Burst	Outputs Odd/Even	Outputs Sync Amplitude	Composite Prop Delay (ns)	V <sub>s</sub> (V)	Supply Current (mA)	Package
ISL59885	✓		Fixed		✓	✓	✓				3	+3 to +5	10	8 Ld SOIC
EL1881	✓			✓	✓		✓	✓	✓		30	+5	1.2	8 Ld PDIP, 8 Ld SOIC
EL1883	✓			✓	✓	✓	✓	✓			30	+3 to +5	1.2	8 Ld SOIC
EL4511		✓	Variable		✓	✓	✓	✓	✓	✓		+3.3 to +5	2.1	24 Ld QSOP
EL4581		✓	Fixed		✓		✓	✓	✓		260	+5	1.7	8 Ld PDIP, 8 Ld SOIC
EL4583		✓	Variable		✓	✓	✓	✓	✓	✓	250	+5	2.5	16 Ld PDIP, 16 Ld SOIC
EL4583A		✓	Variable		✓	✓	✓	✓	✓	✓	250	+5	2.5	16 Ld SOIC

#### DC-RESTORE AMPLIFIER

Device	Channels	3dB Bandwidth (MHz)	I <sub>s</sub> (mA)	Restored Offset (mV)	Diff Gain (%)	Diff Phase (°)	V <sub>s</sub> (V)	Package
ISL4089	1	300	20	10	0.03	0.05	5	8 Ld SOIC

#### VIDEO FRONT END

Device	Sync Separator	Video Amplifier	DC-Restore Function	Slicing Input Adaptive	Color Burst Filter Internal	CSYNC, HSYNC, VSYNC, BURST, and ODD/EVEN Outputs	Outputs Sync Amplitude	Composite Prop Delay (ns)	V <sub>s</sub> (V)	Supply Current (mA)	Package
EL4501	✓	✓	✓	✓	Variable	✓	✓	225	5	10.5	24 Ld QSOP

#### GENLOCKS

Device	PAL Frequency Clocks per Horizontal Line	PAL Frequency Clocks per Horizontal Line CCIR 601	PAL Frequency Clocks per Horizontal Line Sq Pixels	PAL Frequency Clocks per Horizontal Line	NTSC Frequency Clocks per Horizontal Line	NTSC Frequency Clocks per Horizontal Line CCIR 601	NTSC Frequency Clocks per Horizontal Line Sq Pixels	NTSC Frequency Clocks per Horizontal Line	VCO Control Range (V)	V <sub>s</sub> (V)	Supply Current (mA)	Package
EL4584	851	864	944	1135	682	858	780	910	0 to 5	5	2	16 Ld PDIP, 16 Ld SOIC
EL4585	1702	1728	1888	2270	1364	1716	1560	1820	0 to 5	5	2	16 Ld SOIC

#### VIDEO FILTERS

Device	Input Channels	Output Channels	-3dB Filter Cut-Off (MHz)	I <sub>s</sub> (per amp) (mA)	Rail-to-Rail	Gain A <sub>v</sub> (min)	Diff Gain (%)	Diff Phase (°)	Enable	V <sub>s</sub> (V)	Package
ISL59110	1	1	8	2	Y	2	0.1	0.05	Y	+2.5 to +3.6	6 Ld SC-70
ISL59114	2	3	9	1.5	Y	2	0.1	0.5	Y	+2.5 to +3.6	10 Ld uTQFN
ISL59115	3	3	9	1.5	Y	2	0.1	0.5	Y	+2.5 to +3.6	10 Ld uTQFN
ISL59116	2	3	9	1.5	Y	2	0.1	0.5	Y	+2.5 to +3.6	9 Ld CSP T+R
ISL59117	3	3	9	1.5	Y	2	0.1	0.5	Y	+2.5 to +3.6	9 Ld CSP T+R
ISL59118	2	2	9	2.3	Y	2	0.1	0.5	Y	+2.5 to +3.6	10 Ld QFN T+R
ISL59123	3	3	18	1.3	Y	2	0.1	0.5	Y	+2.5 to +3.6	9 Ld WLCSP

### VIDEO AMPLIFIERS

**Single Supply Amplifiers**

ISL59833,  
ISL59837

**200MHz SINGLE SUPPLY VIDEO DRIVER WITH CHARGE PUMP**

The ISL59833 and ISL59837 integrate a charge pump to allow for video black level at ground and negative sync pulses, eliminating the need for a negative power supply, which reduces parts count, board space and BOM cost.

**KEY FEATURES**

- 200MHz Bandwidth: Handles all high resolution video signals.
- High Impedance Outputs: Simple to mux signals
- Reference Input Provided: Precise sync tip control

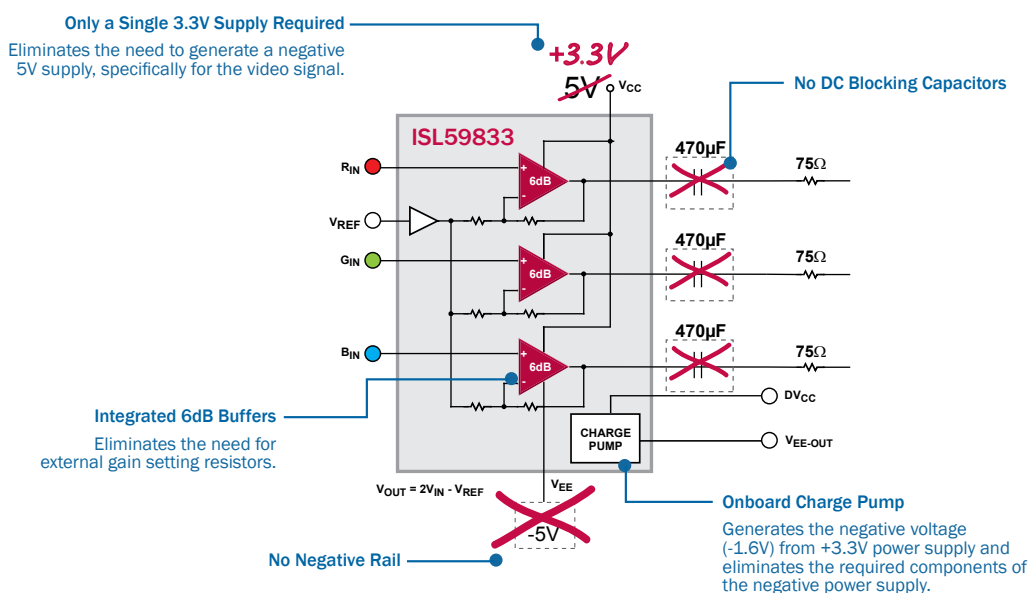

**Selection Table**  
Video Amplifiers

**SINGLE SUPPLY AMPLIFIERS**

Device	Number of Channels	BW (MHz)	SR (V/μs)	V <sub>s</sub> (min) (V)	V <sub>s</sub> (max) (V)	I <sub>s</sub> (per amp) (mA)	Noise V <sub>n</sub> (nV/√Hz)	V <sub>os</sub> (max) (mV)	I <sub>out</sub> (mA)	V <sub>out</sub> (V)	Gain A <sub>v</sub> (min)	Diff Gain (%)	Diff Phase (°)	Enable	Package
ISL59833	3	200	500	3	3.6	32.3	20	25	50	5.1	2	0.07	0.06	Y	16 Ld QSOP
ISL59837	3	200	500	3	3.6	32.3	20	25	50	5.1	2	0.07	0.06	Y	16 Ld QSOP

**FIXED GAIN AMPS**

Device	Number of Channels	BW (MHz)	SR (V/μs)	V <sub>s</sub> (min) (V)	V <sub>s</sub> (max) (V)	I <sub>s</sub> (per amp) (mA)	Noise V <sub>n</sub> (nV/√Hz)	V <sub>os</sub> (max) (mV)	I <sub>out</sub> (mA)	V <sub>out</sub> (V)	Gain A <sub>v</sub> (min)	Diff Gain (%)	Diff Phase (°)	Enable	Package
EL5106	1	350	4500	5	12	1.5	2.8	10	100	7.2	1	0.01	0.01	Y	6 Ld SOT-23, 8 Ld SOIC
EL5108	1	450	4500	5	12	3.5	2	5	135	7.6	1	0.01	0.01	Y	6 Ld SOT-23 T+, 8 Ld SOIC
EL5306	3	350	4500	5	12	1.5	2.8	10	100	7.2	1	0.01	0.01	Y	16 Ld QSOP, 16 Ld SOIC
EL5308	3	450	4500	5	12	3.5	2	5	135	7.6	1	0.01	0.01	Y	16 Ld QSOP, 16 Ld SOIC

# VIDEO PRODUCTS

## SELECTING VIDEO ICs BY FUNCTION



**Selection Table**  
Video Amplifiers  
(Continued)

**CURRENT FEEDBACK AMPS (CFA)**

Device	Number of Channels	BW (MHz)	SR (V/μs)	V <sub>S</sub> (min) (V)	V <sub>S</sub> (max) (V)	I <sub>S</sub> (per amp) (mA)	Noise V <sub>N</sub> (nV/√Hz)	V <sub>OS</sub> (max) (mV)	I <sub>OUT</sub> (mA)	V <sub>OUT</sub> (V)	Gain A <sub>V</sub> (min)	Diff Gain (%)	Diff Phase (°)	Enable	Package
ISL59110	1	8	40	2.5	3.6	2			115	3.2	2	0.1	0.05	Y	6 Ld SC-70
EL5160	1	200	1700	5	10	0.75	4	5	70	6.8	1	0.1	0.1	Y	6 Ld SOT-23, 8 Ld SOIC
EL5161	1	200	1700	5	10	0.75	4	5	70	6.8	1	0.1	0.1	N	5 Ld SOT-23
EL5162	1	500	4000	5	12	1.5	3	5	100	7.2	1	0.05	0.15	Y	6 Ld SOT-23, 8 Ld SOIC
EL5163	1	500	4000	5	12	1.5	3	5	100	7.2	1	0.05	0.15	N	5 Ld SC-70, 5 Ld SOT-23
EL5164	1	600	4700	5	12	5	2.1	5	140	7.6	1	0.01	0.01	Y	6 Ld SOT-23, 8 Ld SOIC
EL5165	1	600	4700	5	12	5	2.1	5	140	7.6	1	0.01	0.01	N	5 Ld SOT-23
EL5166	1	1400	6000	5	12	8.5	1.7	5	160	7.6	1	0.01	0.03	Y	6 Ld SOT-23, 8 Ld SOIC
EL5167	1	1400	6000	5	12	8.5	1.7	5	160	7.6	1	0.01	0.03	N	5 Ld SC-70, 5 Ld SOT-23
EL5360	3	200	1700	5	10	0.75	4	5	70	6.8	1	0.1	0.1	Y	16 Ld QSOP, 16 Ld SOIC
EL5362	3	500	4000	5	12	1.5	3	5	100	7.2	1	0.05	0.15	Y	16 Ld QSOP, 16 Ld SOIC
EL5364	3	600	4700	5	12	5	2.1	5	140	7.6	1	0.01	0.01	Y	16 Ld QSOP, 16 Ld SOIC

**SLEW-ENHANCED VFA**

Device	Number of Channels	BW (MHz)	SR (V/μs)	V <sub>S</sub> (min) (V)	V <sub>S</sub> (max) (V)	I <sub>S</sub> (per amp) (mA)	Noise V <sub>N</sub> (nV/√Hz)	V <sub>OS</sub> (max) (mV)	I <sub>OUT</sub> (mA)	V <sub>OUT</sub> (V)	Gain A <sub>V</sub> (min)	Diff Gain (%)	Diff Phase (°)	Enable	Package
EL5100	1	200	2200	5	10	2.5	10	4	100	6.8	1	0.08	0.1	Y	8 Ld SOIC
EL5102	1	400	2200	5	10	5.2	12	5	150	7.8	1	0.01	0.01	Y	6 Ld SOT-23 T+R, 8 Ld SOIC
EL5103	1	400	2200	5	10	5.2	6	5	150	7.8	1	0.01	0.01	N	5 Ld SOT-23 T+R
EL5104	1	700	7000	5	10	9.5	10	10	160	7.6	1	0.01	0.02	Y	6 Ld SOT-23, 8 Ld SOIC
EL5105	1	700	7000	5	10	9.5	10	10	160	7.6	1	0.01	0.02	N	5 Ld SOT-23
EL5202	2	400	2200	5	10	5.2	12	5	150	7.8	1	0.01	0.01	Y	10 Ld MSOP
EL5203	2	400	2200	5	10	5.2	12	5	150	7.8	1	0.01	0.01	N	8 Ld MSOP, 8 Ld SOIC
EL5204	2	700	7000	5	10	9.5	10	10	160	7.6	1	0.01	0.01	Y	10 Ld MSOP
EL5205	2	700	7000	5	10	9.5	10	10	160	7.6	1	0.01	0.01	N	8 Ld MSOP, 8 Ld SOIC
EL5300	3	200	2200	5	10	2.5	10	4	100	6.8	1	0.01	0.01	Y	16 Ld QSOP
EL5302	3	400	2200	5	10	5.2	12	5	150	7.8	1	0.01	0.01	Y	16 Ld QSOP
EL5304	3	700	7000	5	10	9.5	10	10	160	7.6	1	0.01	0.01	Y	16 Ld QSOP

**DIFFERENTIAL DRIVERS**

Device	Number of Channels	BW (MHz)	SR (V/μs)	V <sub>S</sub> (min) (V)	V <sub>S</sub> (max) (V)	I <sub>S</sub> (per amp) (mA)	Noise V <sub>N</sub> (nV/√Hz)	V <sub>OS</sub> (max) (mV)	I <sub>OUT</sub> (mA)	V <sub>OUT</sub> (V)	Gain A <sub>V</sub> (min)	Diff Gain (%)	Diff Phase (°)	Enable	Package
EL5170	1	100	1100	5	10	7.4	30	25	85	6.9	2	0.1	0.1	Y	8 Ld MSOP, 8 Ld SOIC
EL5171	1	250	800	5	10	8	26	25	90	6.8	1	0.1	0.5	N	8 Ld SOIC
EL5173	1	450	900	5	11	12	25	30	55	7.7	2	0.06	0.13	Y	8 Ld MSOP, 8 Ld SOIC
EL5174	1	550	1100	4.75	11	12.5	21	25	60	7.6	1	0.06	0.13	N	8 Ld SOIC
EL5177	1	550	1100	4.75	11	12.5	21	25	50	7.6	1	0.06	0.13	Y	10 Ld MSOP
EL5370	3	100	1100	5	10	7	30	25	85	6.9	2	0.1	0.1	Y	24 Ld QSOP
EL5371	3	250	800	5	10	8	26	25	90	6.8	1	0.1	0.5	N	28 Ld QSOP
EL5372	3	250	800	5	10	6	26	25	95	7.5	1	0.04	0.4	Y	24 Ld QSOP
EL5373	3	450	1100	4.75	11	12	25	30	55	7.7	2	0.06	0.13	Y	24 Ld QSOP
EL5374	3	550	1100	4.75	11	12.5	21	25	60	7.6	1	0.06	0.13	Y	28 Ld QSOP
EL5378	3	700	1000	4.75	11	12.5	18	30	60	7.4	2	0.06	0.13	Y	28 Ld QSOP

**DIFFERENTIAL RECEIVERS**

Device	Number of Channels	BW (MHz)	SR (V/μs)	V <sub>S</sub> (min) (V)	V <sub>S</sub> (max) (V)	I <sub>S</sub> (per amp) (mA)	Noise V <sub>N</sub> (nV/√Hz)	V <sub>OS</sub> (max) (mV)	I <sub>OUT</sub> (mA)	V <sub>OUT</sub> (V)	Gain A <sub>V</sub> (min)	Diff Gain (%)	Diff Phase (°)	Enable	Package
EL5172	1	250	800	5	10	6	26	25	95	7.5	1	0.04	0.4	Y	8 Ld MSOP, 8 Ld SOIC
EL5175	1	550	600	4.75	11	9.6	21	40	67	7.49	1	0.1	0.1	Y	8 Ld MSOP, 8 Ld SOIC
EL5372	3	250	800	5	10	6	26	25	95	7.5	1	0.04	0.4	Y	24 Ld QSOP
EL5375	3	550	900	4.75	11	9.6	21	30	67	7.49	1	0.1	0.1	Y	24 Ld QSOP



## Intersil Main Offices

Visit [www.intersil.com](http://www.intersil.com) for a complete list of sales representatives and distributors.

### NORTH AMERICA

**WEST COAST**  
Intersil Headquarters  
1001 Murphy Ranch Road  
Milpitas, CA 95035  
(TEL) 408-432-8888  
(FAX) 408-434-5351  
1-888-INTERSIL  
1-888-468-3774

**EAST COAST**  
1650 Robert J Conlan Blvd NE  
Palm Bay, FL 32905  
(TEL) 321-724-7000  
(FAX) 321-729-7320  
1-888-INTERSIL  
1-888-468-3774

### ASIA PACIFIC

Suite 1611, 16/F Tower 2  
Silvercord, 30  
Canton Road,  
Tsimshatsui, Kowloon  
Hong Kong  
(TEL) +852-2709-7600  
(FAX) +852-2730-1433

### JAPAN

6F, Mita Nitto Daibiru  
3-11-36, Mita, Minato-ku  
Tokyo, 108-0073 Japan  
(TEL) +81-3-5439-2311  
(FAX) +81-3-5439-2300

### EUROPE

Oskar-Messter-Str. 29  
D-85737 Ismaning  
Germany  
(TEL) +49-89-46263-0  
(FAX) +49-89-46263-148